

**FLOOD INFORMATION**

FLOOD INFORMATION PER FLOOD INSURANCE RATE MAP  
 (FIRM) 06051C00890 EFFECTIVE DATE: FEBRUARY 18, 2011

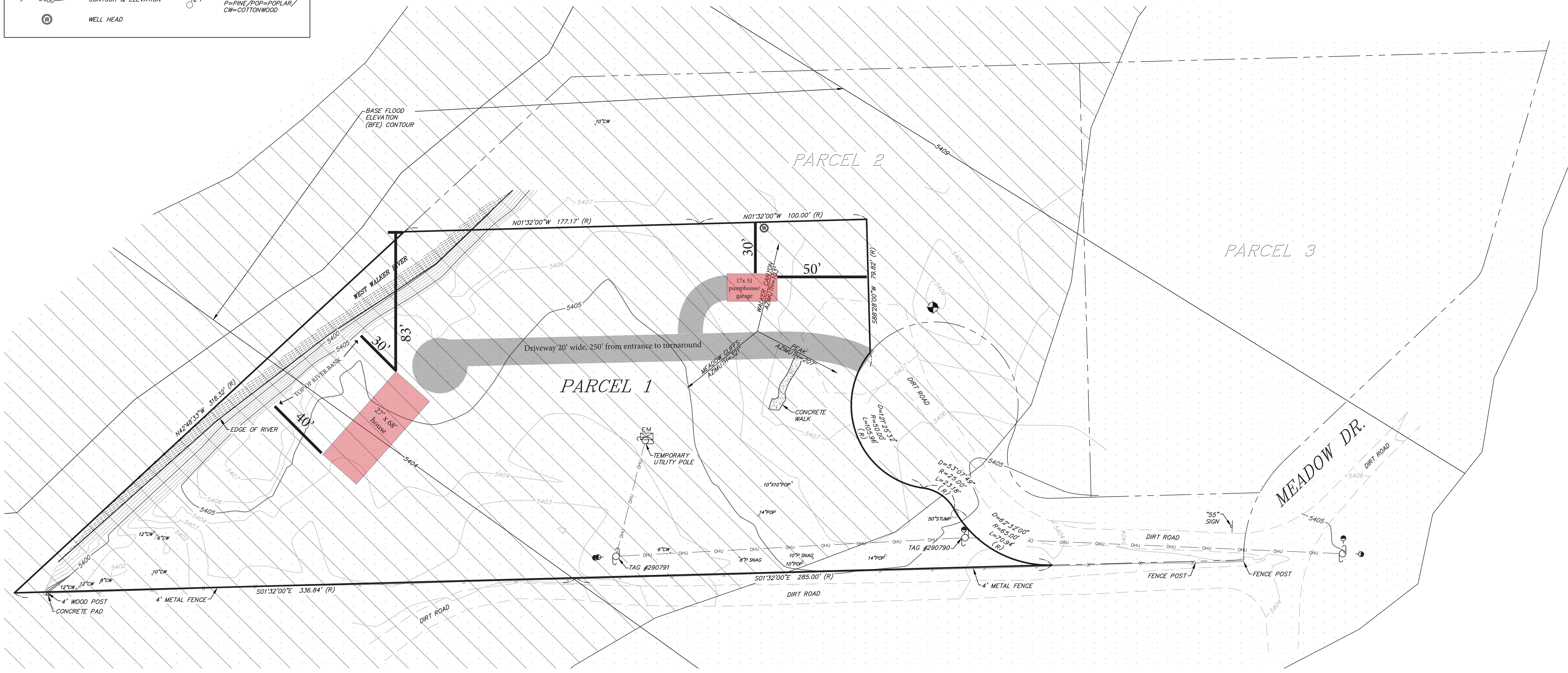
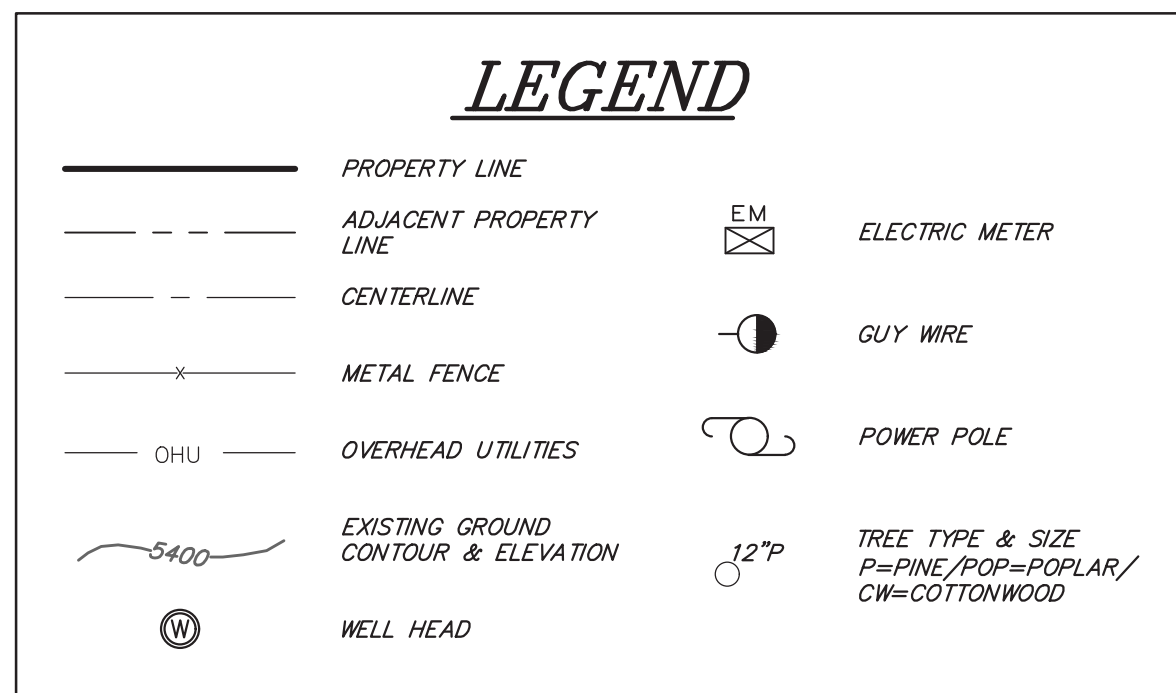
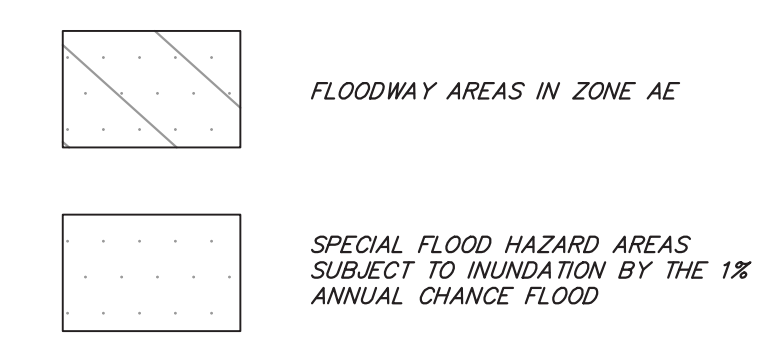

Copyright (C) 2022 by Triad/Holmes Associates  
 All Rights Reserved. This document is intended only for use on the project specified in the title block. Any reproduction of this document or portions of this document without the expressed written consent of Triad/Holmes Associates is prohibited.

REVISIONS: BY:

NO.	DATE	BY	DESCRIPTION

PREPARED FOR:  
 JEFF HINDS  
 MOUNTAIN VIEW BDO  
 (714)673-0369  
 don@mountainviewbdo.com

**55 SPRING COURT**  
**TOPOGRAPHIC SURVEY**  
 WALKER, MONO COUNTY, STATE OF CALIFORNIA

**PARCEL 1**  
 85,755 sq. ft.  
 ±1.97 ACRES

**BOUNDARY INFORMATION**

(R) = RECORD INFORMATION PER PARCEL MAP NO. 31-64,  
 PMB 4 PAGE 2B  
 (M) = MEASURED INFORMATION PER FIELD SURVEY JULY 2022

**BENCHMARK**

TEMPORARY BENCHMARK:  
 PROJECT BENCHMARK IS REBAR ON KNOLL  
 ELEVATION=5409.49'  
 (NAVD 88 DATUM)

I HEREBY STATE THAT I AM A LICENSED LAND SURVEYOR OF THE STATE OF CALIFORNIA, THAT THIS MAP CORRECTLY REPRESENTS A SURVEY MADE UNDER MY SUPERVISION IN JULY 2022, AND THAT THIS MAP DOES NOT INCLUDE EASEMENTS EXCEPT THOSE SPECIFICALLY DELINEATED HEREON.

IF UNDERGROUND UTILITIES, ZONE, SETBACK AND STREET WIDENING DATA ARE SHOWN HEREON, IT IS FOR INFORMATION ONLY, HAVING BEEN OBTAINED FROM AVAILABLE SOURCES NOT CONNECTED WITH THIS CORPORATION. THEREFORE, NO GUARANTEE IS MADE AS TO THE ACCURACY OR COMPLETENESS OF SAID INFORMATION.

ANDREW HOLMES L.S. 4428

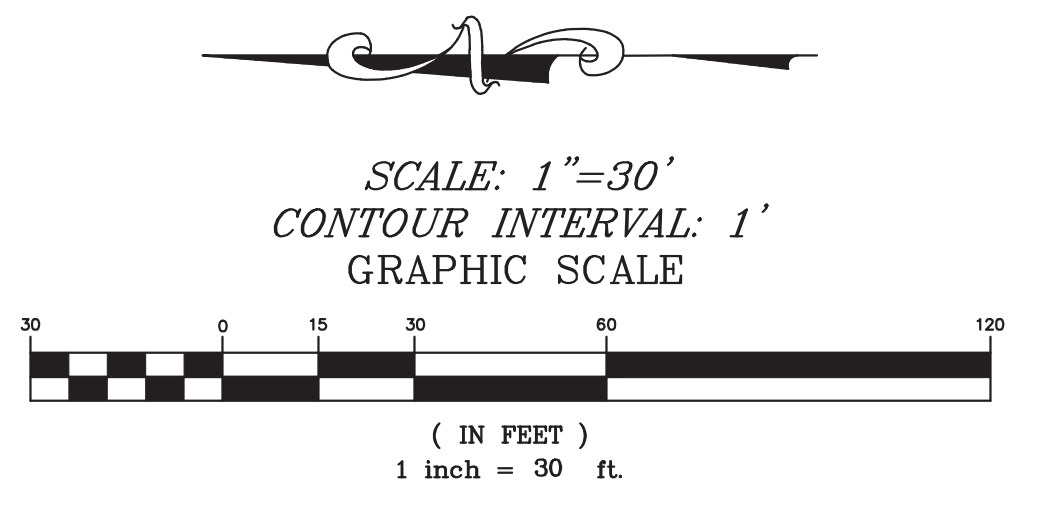

DATE: 8/8/22  
 SCALE: 1"=30'  
 DRAWN: TJP  
 JOB NO.: 01.4441  
 DWS: 1  
 SHEET 1 OF 1

Z:\01 Mammoth\4441 Jeff Hinds 55 Springpar Ct Walker\Parcel 01.4441 Topo.dwg Aug 08 2022 8:53am never