



COUNTY OF MONO
COMMUNITY DEVELOPMENT DEPARTMENT
BUILDING DIVISION

P.O. BOX 8
74 N. SCHOOL ST., ANNEX I
BRIDGEPORT, CA 93546
(760) 932-5420, FAX: 932-5432

comdev@mono.ca.gov
www.monocounty.ca.gov

P.O. BOX 3569
MAMMOTH LAKES, CA 93546
(760) 924-1800, FAX: 924-1801

STANDARD DESIGN FOR VEHICULAR BRIDGES

NOTES TO SUBMITTER

THESE PRESCRIPTIVE DESIGNS ARE INTENDED TO APPLY TO THE MOST COMMON SITUATIONS ENCOUNTERED IN MONO COUNTY. HOWEVER, UNIQUE SITE CONDITIONS OR SUBSTANTIAL DEVIATIONS FROM THESE DESIGNS AS DETERMINED BY THE BUILDING OFFICIAL MAY WARRANT ADDITIONAL DESIGN REQUIREMENTS.

THESE PLANS ARE PRIMARILY FOR THE STRUCTURAL REQUIREMENTS OF VEHICULAR BRIDGES. THE SUBMITTER IS RESPONSIBLE FOR PREPARING AN ARCHITECTURAL PLAN AND SITE PLAN, SHOWING THE ACTUAL LAYOUT OF THE BRIDGE. THE PLANS SHOW WING RETAINING WALLS TRANSITIONING FROM RETAINING AT THE BRIDGE ABUTMENT TO NATURAL GRADE. ACTUAL LAYOUT OF THESE WING WALLS IS TO BE DETERMINED BY THE SUBMITTER BASED UPON ACTUAL SITE CONDITIONS AND THIS LAYOUT SHALL BE INCLUDED IN THE ARCHITECTURAL PLAN. THE PLAN SHALL ALSO SHOW OR NOTE THE STRUCTURAL LAYOUT BASED UPON THE REQUIREMENTS OF THESE PLANS.

LASTLY THE SUBMITTER IS RESPONSIBLE FOR ALL SITE SPECIFIC REQUIREMENTS MONO COUNTY ZONING REQUIREMENTS, FLOOD PLAIN ZONES, CAL-FIRE WILDLAND URBAN INTERFACE REQUIREMENTS, LAHONTAN EROSION CONTROL REQUIREMENTS AND ANY SIMILAR REQUIREMENTS. SUBMITTER SHALL MEET WITH MONO COUNTY BUILDING AND PUBLIC WORKS STAFF TO DETERMINE IF ANY ADDITIONAL REQUIREMENTS FOR SOIL CONDITIONS, EROSION, OR SEDIMENT BUILD-UP ARE REQUIRED.

REQUIREMENTS FOR THIS BRIDGE DESIGN

THIS DESIGN IS LIMITED TO AREAS WITH ROOF SNOW LOADS OF 120 PSF OR LESS. IF DETERMINED BY BUILDING OFFICIAL, THAT THE LOCATION OF THE BRIDGE IS IN A HIGH SNOW LOADING AREA (E.G. BOTTOM OF A CANYON) THAT WOULD CAUSE IT TO BE LOADED BEYOND 120 PSF THIS DESIGN MAY NOT BE APPLICABLE.

THE DESIGN IS LIMITED TO VEHICLES OF A GROSS TONNAGE OF 6,500# OR LESS WHEN USING 4x6 DECKING OR 10,000# OR LESS WHEN USING 6x6 OR 6x8 DECKING. RECLAIMED LUMBER OF EQUIVALENT OR GREATER DIMENSIONS MAY BE USED FOR DECKING, IF SHOWING NO SIGNS OF ROT OR SIMILAR COMPROMISE. THE RATING FOR THE BRIDGE IS TO BE POSTED ON A PERMANENT SIGN, VISIBLE TO THE PRIMARY APPROACH TO THE BRIDGE. PLEASE NOTE: THIS BRIDGE IS NOT INTENDED FOR LARGE TRUCKS, IS NOT RATED TO CAL-FIRE, EDISON OR SIMILAR VEHICLE LOADS. AS SUCH, IT CANNOT BE THE PRIMARY ACCESS TO A STRUCTURE, PLOT OF LAND OR SIMILAR. IF A PRIMARY ACCESS TYPE BRIDGE IS REQUIRED, IT WILL NEED TO BE INDIVIDUALLY DESIGNED BY A LICENSED ENGINEER OR ARCHITECT TO MEET THE SITE CONDITIONS AND LOADING CONDITIONS SPELLED OUT IN AASHTO LRFD BRIDGE DESIGN SPECIFICATIONS, 6TH EDITION AND LOADING AS REQUIRED BY AASHTO AND ANY LOCAL UTILITY OR SERVICE THAT WILL REQUIRE ACCESS TO AN AREA VIA THIS BRIDGE.

IF THE BRIDGE IS TO SEE ANY VEHICULAR TRAFFIC (INCLUDING ATV'S AND SIMILAR) THIS DESIGN SHOULD BE USED. MINIMUM WIDTH IS 6'. MAXIMUM WIDTH AS DETERMINED BY BUILDING OFFICIAL.

IN THE TABLE WE GIVE A RECOMMENDED CAMBER. THIS IS NOT REQUIRED UNLESS AN ASPHALT OR SIMILAR PAVEMENT IS TO SEAL THE TOP SIDE OF THE BRIDGE. ADDITIONAL CAMBER MAY BE CONSIDERED TO BE ADVANTAGEOUS AND CAN BE SPECIFIED.

ALL GLUE LAMINATED BEAMS ARE TO BE SEALED FOR EXPOSURE TO THE ELEMENTS. THE SEAL MAY BE ACHIEVED BY EITHER A PENETRATING SEALANT (WHICH MAY BE FACTORY OR FIELD APPLIED) OR A COATING SEALANT. ALL SURFACES ARE TO BE SEALED PRIOR TO PLACEMENT, AND IF FACTORY SEALED, ANY CUT ENDS MUST HAVE SEALANT APPLIED TO THEM. SUBMITTER TO NOTE ON PLANS TYPE OF SEALANT TO BE USED.

IF THE BRIDGE IS TO HAVE A PAVEMENT COATING OVER THE DECKING, THE DECKING SHOULD BE OF DECAY RESISTANT MATERIAL (RATED REDWOOD OR PRESSURE TREATED).

IF THE BRIDGE SPANS MORE THAN 16', BLOCKING BETWEEN JOISTS SHOULD BE PROVIDED AT THE CENTER OF THE SPAN, OR FOR A 20'-25' SPAN PROVIDE BLOCKING AT APPROXIMATELY THE THIRD POINTS. BLOCKING TO BE FULL DEPTH OF JOISTS (AND PROBABLY OF JOIST MATERIAL, THOUGH OTHER FULL DEPTH BLOCKING CAN BE APPROVED BY THE BUILDING OFFICIAL).

MONO COUNTY PROVIDES THESE PLANS TO THE PUBLIC AS A COURTESY AND WITHOUT ANY WARRANTIES, EXPRESS OR IMPLIED, REGARDING THEIR FITNESS FOR ANY PARTICULAR APPLICATION. AMONG OTHER THINGS, MONO COUNTY DOES NOT REPRESENT OR WARRANT THAT THE DESIGNS WITHIN SAID PLANS ARE FREE FROM FLAWS OR DEFECTS. ANYONE UTILIZING THESE PLANS DOES SO AT THEIR OWN RISK AND WAIVES ANY CLAIMS AGAINST MONO COUNTY ARISING FROM SUCH USE.



COUNTY OF MONO
COMMUNITY DEVELOPMENT DEPARTMENT
BUILDING DIVISION

P.O. BOX 8
 74 N. SCHOOL ST., ANNEX I
 BRIDGEPORT, CA 93546
 (760) 932-5420, FAX: 932-5432

comdev@mono.ca.gov
 www.monocounty.ca.gov

P.O. BOX 3569
 MAMMOTH LAKES, CA 93546
 (760) 924-1800, FAX: 924-1801

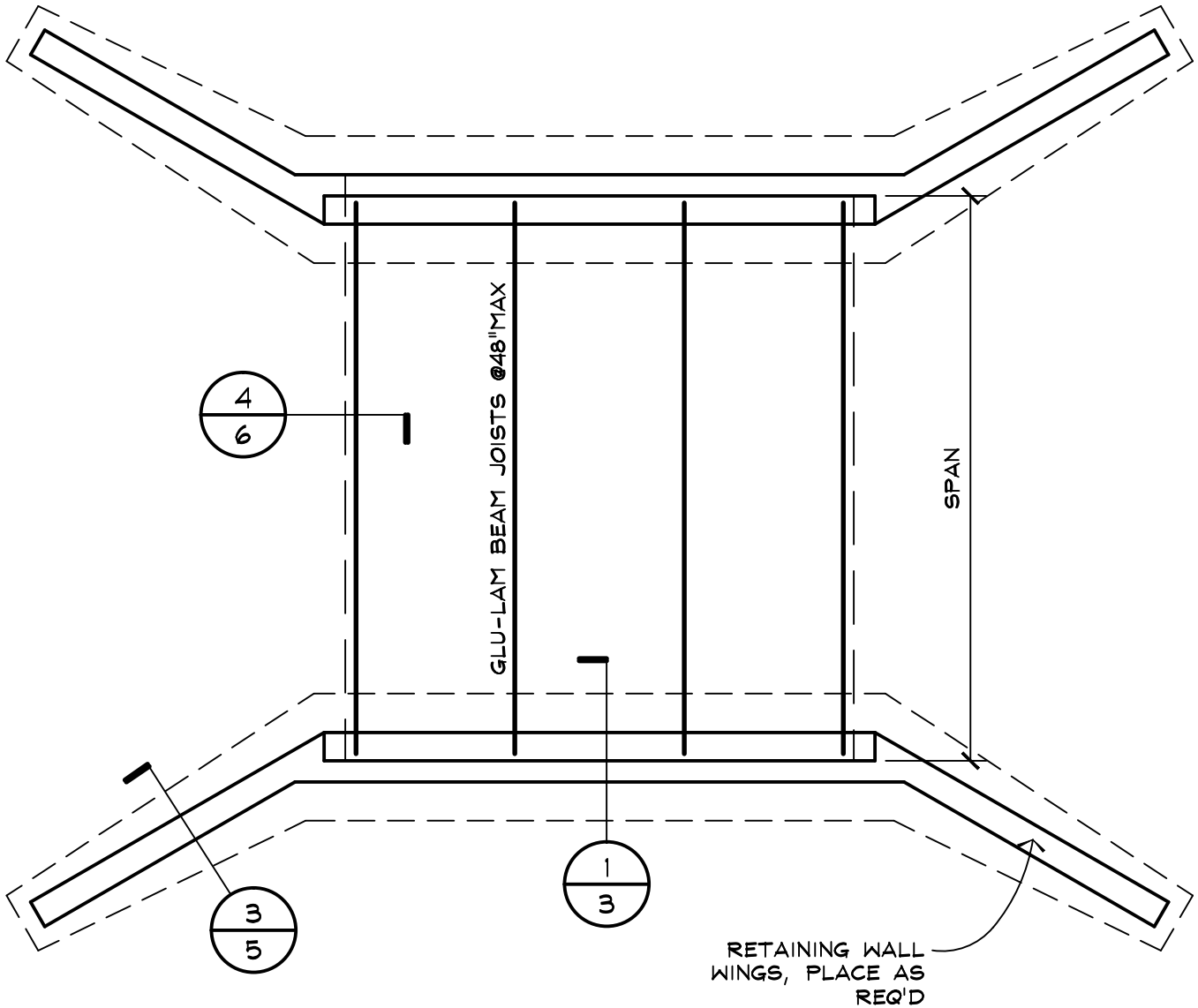

**BRIDGE FOUNDATION
 AND FRAMING PLAN**

1/4" = 1'-0"

JOIST SIZING FOR SPANS, VEHICULAR BRIDGES		
SPAN	GLULAM JOIST SIZE	RECOMMENDED CAMBER
13'	5 1/8 x 10 1/2	0.27"
15'	5 1/8 x 12	0.38"
17'	5 1/8 x 13 1/2	0.49"
19'	5 1/8 x 15	0.60"
21'	6 3/4 x 15	0.73"
24'	6 3/4 x 16 1/2	0.86"



COUNTY OF MONO
COMMUNITY DEVELOPMENT DEPARTMENT
BUILDING DIVISION

P.O. BOX 8
74 N. SCHOOL ST., ANNEX I
BRIDGEPORT, CA 93546
(760) 932-5420, FAX: 932-5432

comdev@mono.ca.gov
www.monocounty.ca.gov

P.O. BOX 3569
MAMMOTH LAKES, CA 93546
(760) 924-1800, FAX: 924-1801

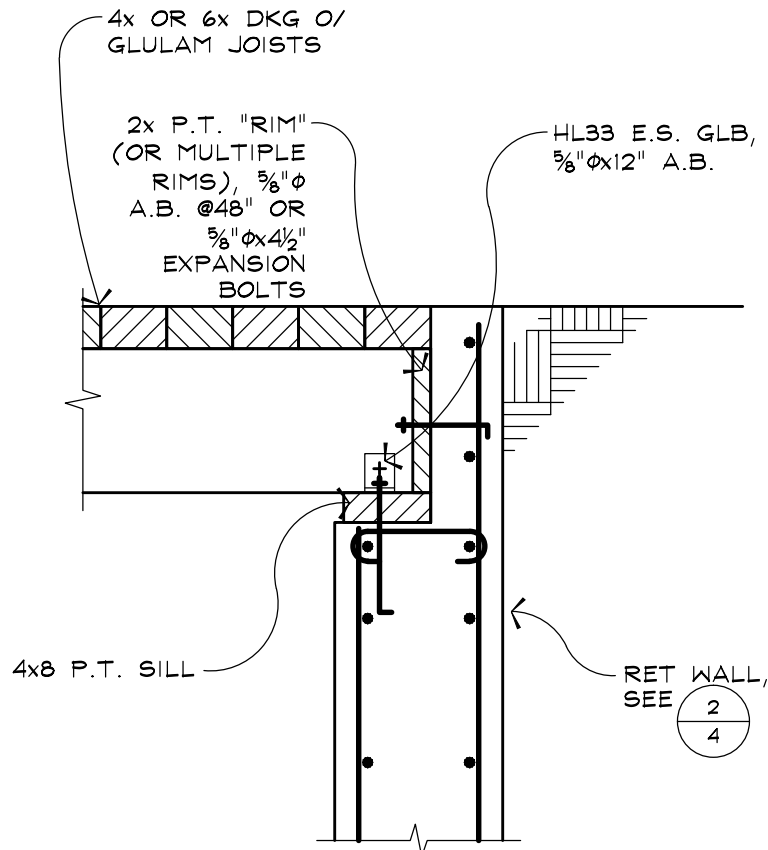

1

FDN-EXT_4xDKG-GLBJST-RETWL_HL_S-PERP_U01



COUNTY OF MONO

COMMUNITY DEVELOPMENT DEPARTMENT

BUILDING DIVISION

P.O. BOX 8
74 N. SCHOOL ST., ANNEX I
BRIDGEPORT, CA 93546
(760) 932-5420, FAX: 932-5432

comdev@mono.ca.gov
www.monocounty.ca.gov

P.O. BOX 3569
MAMMOTH LAKES, CA 93546
(760) 924-1800, FAX: 924-1801

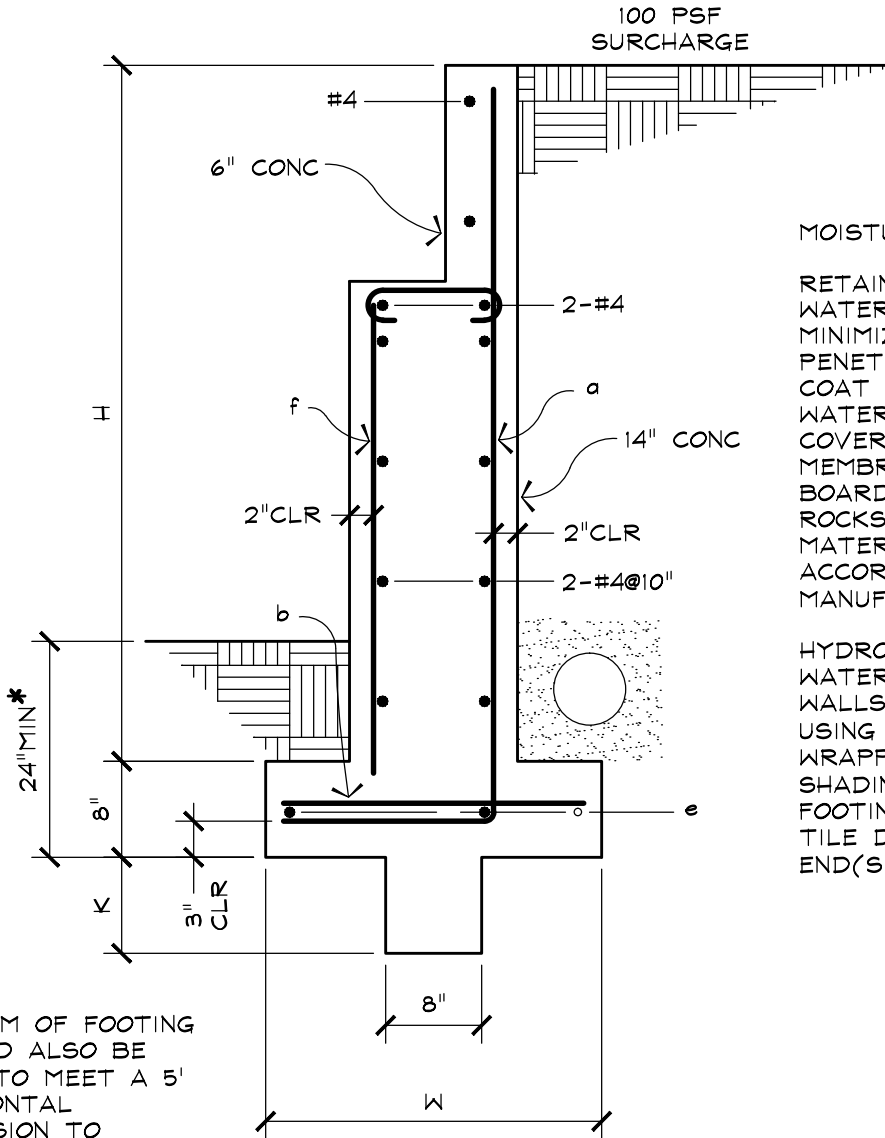

MOISTURE PROTECTION

RETAINING WALLS SHALL BE WATER-PROOFED BELOW GRADE TO MINIMIZE EARTH MOISTURE PENETRATION THROUGH THE WALL. COAT WITH THOROSEAL WATERPROOFING COMPOUND, COVER WITH BITUTHEND MEMBRANE, COVER WITH CELOTEX BOARD TO PREVENT DAMAGE BY ROCKS, ETC. IN BACKFILL. ALL MATERIALS SHALL BE APPLIED IN ACCORDANCE WITH MANUFACTURER'S SPECIFICATIONS.

HYDROSTATIC PRESSURE FROM WATER BEHIND ALL RETAINING WALLS SHALL BE ALLEVIATED BY USING 6" MINIMUM DRAINAGE TILE, WRAPPED IN CRUSHED ROCK SHADING (ONE SQUARE FOOT) AT FOOTING LEVEL WITH DRAINAGE TILE DRAINING TO DAYLIGHT AT END(S) OF WALL.

* BOTTOM OF FOOTING SHOULD ALSO BE ABLE TO MEET A 5' HORIZONTAL DIMENSION TO DAYLIGHT, WHICH COULD POSSIBLY INCREASE THIS DIMENSION

WALLS RETAINING 2'-7' @100 PSF SURCHARGE

H	W	K	a	b	e	f
2'	24"	-	#4@16"	#4@16"	2-#4	#3@24"
3'	24"	-	#4@16"	#4@16"	2-#4	#3@24"
4'	30"	-	#4@16"	#4@16"	2-#4	#3@24"
5'	36"	-	#4@16"	#4@16"	3-#4	#3@24"
6'	42"	8"	#4@16"	#4@16"	3-#4	#3@24"
7'	50"	8"	#4@16"	#4@16"	3-#4	#4@24"

EFP = 30 PCF FOR CANTILEVER CONDITION
EFP = 55 PCF FOR RESTRAINED CONDITION



COUNTY OF MONO

COMMUNITY DEVELOPMENT DEPARTMENT

BUILDING DIVISION

P.O. BOX 8
74 N. SCHOOL ST., ANNEX I
BRIDGEPORT, CA 93546
(760) 932-5420, FAX: 932-5432

comdev@mono.ca.gov
www.monocounty.ca.gov

P.O. BOX 3569
MAMMOTH LAKES, CA 93546
(760) 924-1800, FAX: 924-1801

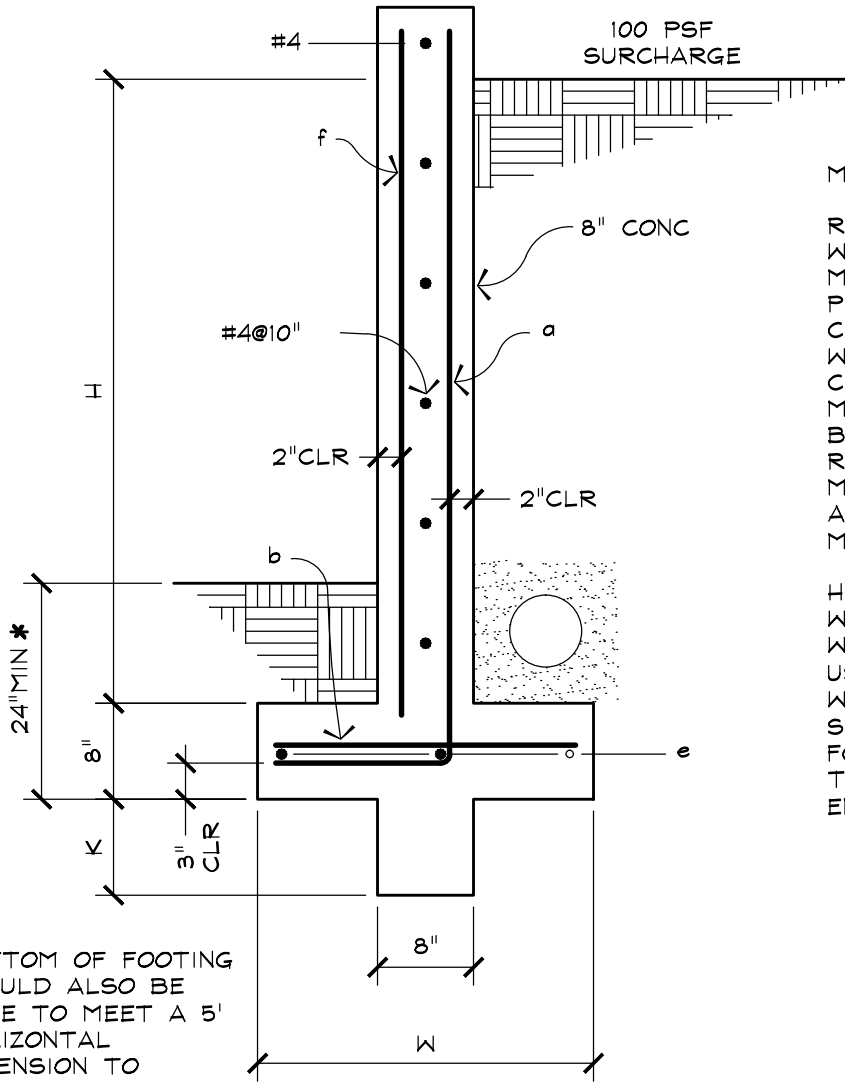

MOISTURE PROTECTION

RETAINING WALLS SHALL BE WATER-PROOFED BELOW GRADE TO MINIMIZE EARTH MOISTURE PENETRATION THROUGH THE WALL. COAT WITH THOROSEAL WATERPROOFING COMPOUND, COVER WITH BITUTHEND MEMBRANE, COVER WITH CELOTEX BOARD TO PREVENT DAMAGE BY ROCKS, ETC. IN BACKFILL. ALL MATERIALS SHALL BE APPLIED IN ACCORDANCE WITH MANUFACTURER'S SPECIFICATIONS.

HYDROSTATIC PRESSURE FROM WATER BEHIND ALL RETAINING WALLS SHALL BE ALLEVIATED BY USING 6" MINIMUM DRAINAGE TILE, WRAPPED IN CRUSHED ROCK SHADING (ONE SQUARE FOOT) AT FOOTING LEVEL WITH DRAINAGE TILE DRAINING TO DAYLIGHT AT END(S) OF WALL.

* BOTTOM OF FOOTING SHOULD ALSO BE ABLE TO MEET A 5' HORIZONTAL DIMENSION TO DAYLIGHT, WHICH COULD POSSIBLY INCREASE THIS DIMENSION

WALLS RETAINING 2'-7' @100 PSF SURCHARGE

H	W	K	a	b	e	f
2'	18"	-	#4@16"	#4@16"	2-#4	#3@24"
3'	24"	-	#4@16"	#4@16"	2-#4	#3@24"
4'	30"	-	#4@16"	#4@16"	2-#4	#3@24"
5'	36"	-	#4@16"	#4@16"	3-#4	#3@24"
6'	42"	8"	#4@16"	#4@16"	3-#4	#3@24"
7'	50"	8"	#4@16"	#4@16"	3-#4	#4@24"

EFP = 30 PCF FOR CANTILEVER CONDITION
EFP = 55 PCF FOR RESTRAINED CONDITION



COUNTY OF MONO
COMMUNITY DEVELOPMENT DEPARTMENT
BUILDING DIVISION

P.O. BOX 8
74 N. SCHOOL ST., ANNEX I
BRIDGEPORT, CA 93546
(760) 932-5420, FAX: 932-5432

comdev@mono.ca.gov
www.monocounty.ca.gov

P.O. BOX 3569
MAMMOTH LAKES, CA 93546
(760) 924-1800, FAX: 924-1801

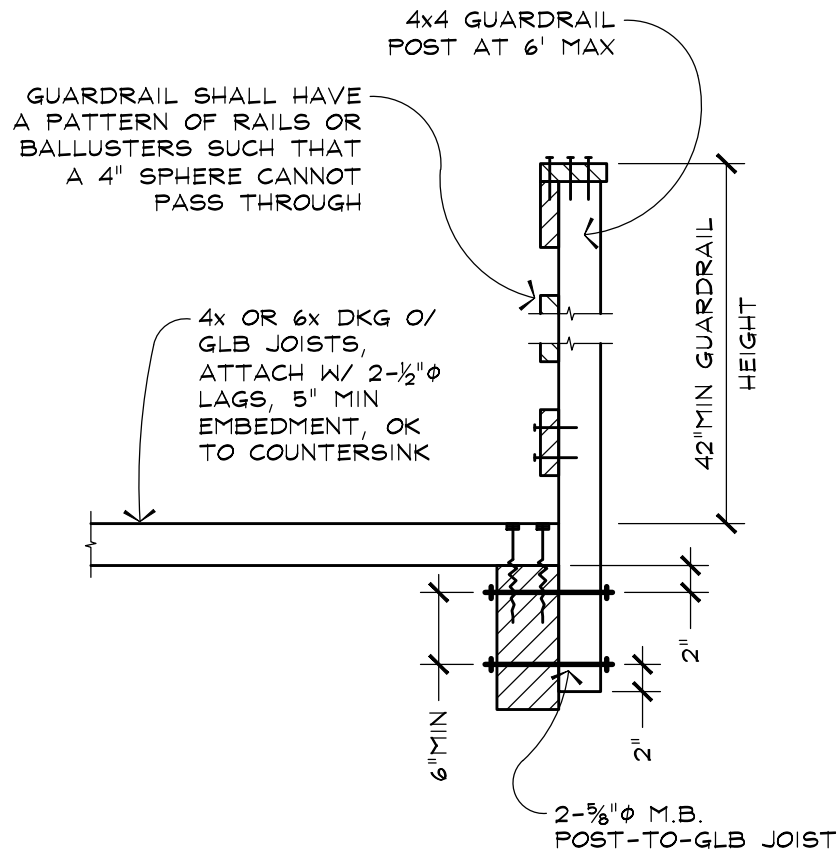

4

FLR-DCK_GUARDRAIL-4xDKG-GLBDJ_2MB_S-PERP_U01



COUNTY OF MONO
COMMUNITY DEVELOPMENT DEPARTMENT
BUILDING DIVISION

P.O. BOX 8
74 N. SCHOOL ST., ANNEX I
BRIDGEPORT, CA 93546
(760) 932-5420, FAX: 932-5432

comdev@mono.ca.gov
www.monocounty.ca.gov

P.O. BOX 3569
MAMMOTH LAKES, CA 93546
(760) 924-1800, FAX: 924-1801

GENERAL REQUIREMENTS:

1. CODES AND REFERENCES

- a. ALL MATERIALS AND WORKMANSHIP SHALL CONFORM TO THE REQUIREMENTS OF THE 2010 CALIFORNIA BUILDING CODE (C.B.C.) AND 2010 CALIFORNIA RESIDENTIAL CODE (C.R.C.) BASED UPON THE 2009 INTERNATIONAL BUILDING CODE (I.B.C.) AND 2009 INTERNATIONAL RESIDENTIAL CODE (I.R.C.)
- b. A THOROUGH PLANCHECK SHALL BE MADE BY A QUALIFIED REPRESENTATIVE OF THE BUILDING DEPARTMENT PRIOR TO THE ISSUANCE OF A BUILDING PERMIT. CORRECTIONS, IF ANY, SHALL BE MADE ONLY BY THE SUBMITTER OR HIS REPRESENTATIVE. ONCE THE BUILDING PERMIT HAS BEEN ISSUED NO CHANGES OR DEVIATIONS SHALL BE MADE WITHOUT THE WRITTEN APPROVAL OF THE SUBMITTER, LEST AN UNSAFE OR UNLAWFUL CONDITION BE CREATED. CONTRACTOR SHALL COMPLY WITH ANY CODE OR LEGAL VIOLATION WHICH MIGHT BE POINTED OUT BY THE BUILDING INSPECTOR.
- c. WHERE REFERENCE IS MADE TO VARIOUS TEST STANDARDS FOR MATERIALS, SUCH STANDARDS SHALL BE THE LATEST EDITION, AND/OR ADDENDUM. THESE STANDARDS WILL BE REFERRED TO IN ABBREVIATED FORM AS LISTED BELOW:

ACI	AMERICAN CONCRETE INSTITUTE
AISC	AMERICAN INSTITUTE OF STEEL CONSTRUCTION
ANSI	AMERICAN NATIONAL STANDARDS INSTITUTE
ASTM	AMERICAN SOCIETY OF TESTING MATERIALS
AWS	AMERICAN WELDING SOCIETY
ICC	INTERNATIONAL CODE COUNCIL

- d. CONTRACTOR SHALL CHECK AND VERIFY ALL DIMENSIONS AND CONDITIONS ON THE JOB SITE AND REPORT ANY ERRORS, OMISSIONS, OR POSSIBLE DISCREPANCIES TO THE SUBMITTER PRIOR TO PROCEEDING WITH THE WORK. SPECIAL CARE SHALL BE GIVEN SITE AND BUILDING LAYOUT THEREUPON.

2. PROTECTION BY CONTRACTOR

- a. CONTRACTOR SHALL LOCATE ALL EXISTING UTILITIES WHETHER OR NOT SHOWN ON THE DRAWINGS AND PROTECT THEM FROM DAMAGE.
- b. HE SHALL COMPLY WITH ALL LAWS AND REGULATIONS REGARDING PROTECTION OF THE PUBLIC AND THE WORKMEN DURING CONSTRUCTION.
- c. HE SHALL BEAR ALL EXPENSE OF REPAIR OR REPLACEMENT RELATIVE TO THE PROSECUTION OF THIS WORK.



COUNTY OF MONO
COMMUNITY DEVELOPMENT DEPARTMENT
BUILDING DIVISION

P.O. BOX 8
74 N. SCHOOL ST., ANNEX I
BRIDGEPORT, CA 93546
(760) 932-5420, FAX: 932-5432

comdev@mono.ca.gov
www.monocounty.ca.gov

P.O. BOX 3569
MAMMOTH LAKES, CA 93546
(760) 924-1800, FAX: 924-1801

CONCRETE AND EMBEDDED ITEMS (C.B.C. CHAPTER 19):

1. ALL CONCRETE SHALL BE MIXED, FORMED AND PLACED ACCORDING TO THE AMERICAN CONCRETE INSTITUTE (ACI) BUILDING CODE REQUIREMENTS FOR REINFORCED CONCRETE, ACI 318-08.
2. CONCRETE SHALL HAVE A MINIMUM ULTIMATE COMPRESSIVE STRENGTH OF 2500 PSI AT 28 DAYS. USE 6 SACKS OF CEMENT (MINIMUM) PER YARD OF CONCRETE FOR WEATHER DURABILITY. EXCEPTIONS SHALL BE NOTED HEREIN OR ON PLANS.
3. CEMENT FOR CONCRETE SHALL BE A STANDARD BRAND "PORTLAND CEMENT," MEETING THE REQUIREMENTS OF ASTM C150, TYPE I OR II, LOW ALKALI.
4. AGGREGATES FOR CONCRETE SHALL MEET THE REQUIREMENTS OF ASTM C33.
5. CONCRETE SHALL BE MACHINE-MIXED USING A MAXIMUM OF 7 $\frac{1}{2}$ GALLONS OF WATER PER SACK OF CEMENT. READYMIX CONCRETE SHALL BE MIXED AND DELIVERED IN ACCORDANCE WITH ASTM C94.
6. CONTRACTOR MAY USE A WATER REDUCING ADMIXTURE CONFORMING TO ASTM C494, PROVIDED SUBMITTER IS NOTIFIED IN WRITING IN ADVANCE OF ITS USE.
7. ALL REINFORCING STEEL, ANCHOR BOLTS, DOWELS EMBEDDED PIPES AND CONDUIT SHALL BE SECURELY FASTENED IN THE FORMS BEFORE CONCRETE IS POURED. ADEQUATE CLEANOUTS SHALL BE PROVIDED IN THE BOTTOM OF THE CONCRETE FORMS FOR PROPER CLEANING AND INSPECTION.
8. UNLESS NOTED OTHERWISE ON THE PLAN, MINIMUM EMBEDMENT OF ANCHOR BOLTS (A.B.) SHALL BE 7" IN HORIZONTAL CONCRETE SURFACES (FOOTINGS, etc) AND 4" INTO VERTICAL CONCRETE SURFACES (WALLS, etc). ALL BOLTS SHALL HAVE A 4 DIAMETER, 90° BEND AT EMBEDDED END. ANCHOR BOLTS SHALL BE SPACED 12 DIAMETERS, MINIMUM.
9. EXPANSION BOLTS, ITW RAMSET/"RED HEAD," etc, MAY BE USED IN LIEU OF CAST-IN-PLACE BOLTS WHERE SPECIAL CONDITIONS WARRANT THEIR USE, PROVIDED WRITTEN APPROVAL OF THE MONO COUNTY BUILDING DEPARTMENT IS OBTAINED.
10. FOOTING DOWELS SHALL MATCH VERTICAL WALL STEEL. LAP 36 DIAMETERS, MINIMUM.
11. CEMENT GROUT AND DRY-PACK GROUT SHALL CONSIST OF 1 PART CEMENT TO 2 $\frac{1}{2}$ PARTS FINE AGGREGATE BY VOLUME. ADD SUFFICIENT WATER TO MAKE THE MIXTURE FLOW UNDER ITS OWN WEIGHT. FOR USE AS DRY-PACK CONCRETE (HAND-PLACED BELOW METAL OR WOOD PLATES) ADD WATER TO MAKE A STIFF MIXTURE WHICH CAN BE MOLDED INTO A SPHERE. GROUT SHALL ATTAIN A MINIMUM ULTIMATE COMPRESSIVE STRENGTH OF 2500 PSI AT 28 DAYS.



COUNTY OF MONO
COMMUNITY DEVELOPMENT DEPARTMENT
BUILDING DIVISION

P.O. BOX 8
74 N. SCHOOL ST., ANNEX I
BRIDGEPORT, CA 93546
(760) 932-5420, FAX: 932-5432

comdev@mono.ca.gov
www.monocounty.ca.gov

P.O. BOX 3569
MAMMOTH LAKES, CA 93546
(760) 924-1800, FAX: 924-1801

REINFORCING STEEL (C.B.C. CHAPTER 19):

1. ALL REINFORCING STEEL SHALL MEET THE REQUIREMENTS OF, AND BE PLACED IN ACCORDANCE WITH, THE AMERICAN CONCRETE INSTITUTE (ACI) BUILDING CODE REQUIREMENTS FOR REINFORCED CONCRETE, ACI 318-08.
2. REINFORCING STEEL SHALL BE INTERMEDIATE GRADE DEFORMED U.N.O. (EXCEPT #2 TIES OR STIRRUPS) BARS CONFORMING TO ASTM A615, GRADE 40 TYPICALLY. LAP BARS A MINIMUM OF 30 DIAMETERS. WHERE GRADE 60 (HARD GRADE) IS REQUIRED ON PLANS, LAP 36 DIAMETERS. STAGGER LAPS WHERE PERMISSIBLE.
3. ALL WELDED REBAR TO BE GRADE A706.
4. WIRE MESH SHALL CONFORM TO ASTM A185. LAP 8" MINIMUM.
5. LOW HYDROGEN, E70 SERIES, WELDING RODS SHALL BE USED FOR ALL WELDING OF REINFORCING BARS COMPLYING WITH AWS D1.4.
6. PROVIDE DOWELS IN FOOTINGS AND/OR GRADE BEAMS THE SAME SIZE AND NUMBER AS VERTICAL WALL REINFORCING. PROJECT DOWELS EQUAL TO STANDARD LAP SPLICE AND WIRE TO VERTICAL STEEL.
7. #5 OR LARGER REBAR SHALL NOT BE RE-BENT WITHOUT APPROVAL.
8. MINIMUM CONCRETE COVER SHALL BE:
 - 3" CONCRETE POURED AGAINST EARTH, BOTTOM AND SIDES.
 - 2" FORMED CONCRETE WHICH WILL REMAIN IN CONTACT WITH EARTH, INCLUDING STEEL IN TOP SURFACES OF FOOTINGS AND WALL SURFACES IN CONTACT WITH EARTH.
 - 1½" BEAMS, MEASURED TO MAIN STEEL; COLUMNS, MEASURED TO TIES OR SPIRALS; EXPOSED FACES OF WALLS ABOVE GRADE OR THEIR SURFACES NOT IN CONTACT WITH EARTH.
 - 1" TOP SURFACES OF SLABS DIRECTLY EXPOSED TO THE ELEMENTS.
 - ¾" INTERIOR SLABS; INSIDE FACES OF WALLS.



COUNTY OF MONO
COMMUNITY DEVELOPMENT DEPARTMENT
BUILDING DIVISION

P.O. BOX 8
74 N. SCHOOL ST., ANNEX I
BRIDGEPORT, CA 93546
(760) 932-5420, FAX: 932-5432

comdev@mono.ca.gov
www.monocounty.ca.gov

P.O. BOX 3569
MAMMOTH LAKES, CA 93546
(760) 924-1800, FAX: 924-1801

WOOD CONSTRUCTION (C.B.C. CHAPTER 23):

1. STRUCTURAL LUMBER SHALL BE GRADE-MARKED DOUGLAS FIR-LARCH (Df-L) PER STANDARD GRADING RULES NO. 17, WCLIB, AND STANDARD GRADING RULES, WWPA.

	<u>GRADE</u>
JOISTS, BEAMS, PURLINS AND POSTS 4" AND WIDER	#1
JOISTS AND SUB-PURLINS 2" WIDE, 2x6 OR DEEPER STUDS, TOP PLATES, SILL PLATES AT BEARING WALLS, AND LEDGERS OF ALL WIDTHS	#2
2x4 AND 3x4 STUDS	STUD
BLOCKING, NON-BEARING SILL PLATES AND MISC.	#3

2. COMMON NAILS SHALL BE USED. BOX NAILS, IF INCREASED IN NUMBER BY 33%, MAY ALSO BE USED.
3. SILLS OR PLATES BEARING ON CONCRETE OR MASONRY WHICH IS WITHIN 48" OF EARTH SHALL BE PRESSURE TREATED (P.T.). SILLS SHALL BE BOLTED TO THE FOUNDATION WITH $\frac{5}{8}$ " DIAMETER x 10" BOLTS AT 4'-0" O.C., 12" MIN, FROM ENDS, OR 2 BOLTS MIN PER PIECE, U.N.O.
4. FIREBLOCKING, 2" THICK, SHALL BE PLACED IN STUD WALLS AT CEILING AND FLOOR LEVELS, AT EACH 10' HEIGHT OF STUDS, AND BETWEEN STAIR STRINGERS AT SUPPORTS.
5. JOISTS AND RAFTERS SHALL BE BLOCKED AT SUPPORTS AND BRIDGED OR BLOCKED AT INTERVALS OF 8' WHERE JOISTS ARE 2x12'S OR DEEPER.
6. JOISTS UNDER BEARING PARTITIONS (ONE STORY ABOVE) SHALL BE DOUBLED; TRIPLED FOR TWO STORIES ABOVE.
7. PLYWOOD SHALL BE PER APA PS 1-07. PROVIDE A $\frac{1}{8}$ " SPACE BETWEEN ALL JOINTS.
8. LAGBOLTS (AND SCREWS) SHALL BE PRE-DRILLED $\frac{1}{16}$ " LESS THAN SHANK DIAMETER TO FULL DEPTH AND SCREWED (NOT DRIVEN) INTO PLACE.
9. CUT WASHERS SHALL BE PLACED UNDER HEADS AND NUTS OF ALL BOLTS AND UNDER HEADS OF LAGBOLTS. CUT WASHER SHALL BE USED FOR BOLTS CONNECTING WOOD LEDGERS TO CONCRETE OR MASONRY WALLS.



COUNTY OF MONO
COMMUNITY DEVELOPMENT DEPARTMENT
BUILDING DIVISION

P.O. BOX 8
74 N. SCHOOL ST., ANNEX I
BRIDGEPORT, CA 93546
(760) 932-5420, FAX: 932-5432

comdev@mono.ca.gov
www.monocounty.ca.gov

P.O. BOX 3569
MAMMOTH LAKES, CA 93546
(760) 924-1800, FAX: 924-1801

10. WHERE REQUIRED IN ALL CONDITIONS EXCEPT SILL PLATE ANCHOR BOLTS, MALLEABLE IRON (M.I. WA.) OR PLATE (PL. WA.) WASHERS SHALL BE SIZED AS FOLLOWS:

<u>BOLT DIA.</u>	<u>M.I. WA.</u>	<u>PL. WA.</u>
1/2"	1/4"x2 1/2" DIA.	3/16"x2" SQ
5/8"	5/16"x2 3/4"	1/4"x2 1/2"
3/4"	7/16"x3"	5/16"x2 3/4"
7/8"	7/16"x3 1/2"	5/16"x3"
1"	1/2"x3 3/4"	3/8"x3 1/2"

11. SEE NOTES BELOW SHEAR PANEL SCHEDULE FOR REQUIREMENTS FOR WASHERS AT SILL PLATE ANCHOR BOLTS.

12. ALL STRUCTURAL PLYWOOD NAILING (ROOF, FLOOR AND WALLS) SHALL BE INSPECTED BY THE BUILDING INSPECTOR PRIOR TO COVERING.

13. STUDS IN BEARING WALLS SHALL NOT BE NOTCHED UNLESS SPECIFICALLY DETAILED BY IN THESE PLANS, OR BY A LICENSED ARCHITECT OR PROFESSIONAL ENGINEER.

14. FRAMING HARDWARE SHALL BE SIMPSON STRONG-TIE®. REFER TO SIMPSON CATALOG C-2013 FOR INSTALLATION INFORMATION. USE EXACT TYPE, SIZE AND NUMBER OF FASTENERS SPECIFIED IN CATALOG.

GLULAM BEAMS AND POSTS (C.B.C. CHAPTER 23):

1. ALL GLUED LAMINATED BEAMS AND POSTS SHALL BE DOUGLAS FIR-LARCH (Df-L) AND SHALL COMPLY WITH ANSI/AITC STANDARD A190.1 AND ASTM D3737, "DESIGN AND MANUFACTURE OF STRUCTURAL GLUED-LAMINATED TIMBER."
2. BEAMS SHALL BE COMBINATION 24f-V4, U.N.O. ALL GLULAM BEAMS WITH CANTILEVERS SHALL BE 24f-V8.
3. GLULAM BEAMS LOCATED INSIDE BUILDINGS SHALL BE SPECIFIED FOR DRY CONDITIONS OF USE AND GLULAM BEAMS LOCATED OUTSIDE OF BUILDINGS SHALL BE SPECIFIED FOR WET CONDITIONS OF USE, UNLESS NOTED OTHERWISE.
4. FABRICATOR SHALL SUBMIT A CERTIFICATE OF INSPECTION TO THE BUILDING DEPARTMENT FOR EACH BEAM AND POST PRIOR TO ERECTION.
5. CAMBER ASSUMED TO BE STOCK CAMBER (TYPICALLY 3,500 FT. RADIUS) UNLESS NOTED ON GLU-LAM CALLOUT ON PLANS.